

Solving your swarf control problems!

New

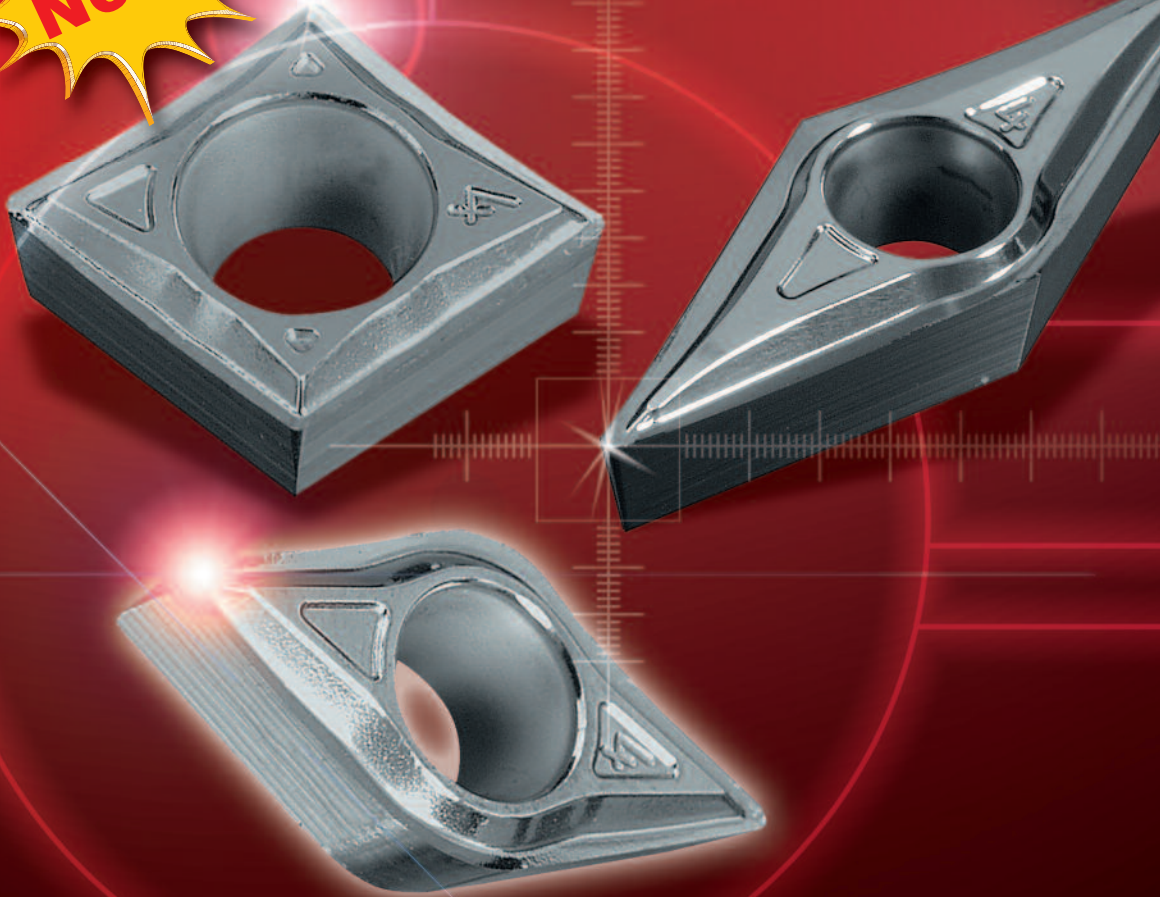

ARNO®
WERKZEUGE

www.arno.de

Periphery ground and
polished surface =
Economical and reliable
performance

High positive «ASF» geometries

ASF geometry in grade AM5015 offer excellent swarf control for finishing.

Improved swarf control and excellent results are achieved by using the new enhanced **ASF-geometry** and grade **AM5015**. Outstanding results are achieved due to the improved cutting edge stability and the wear resistance of the new coated **AM5015** grade utilised on this new insert program.



CCGT / DCGT >>

CCGT

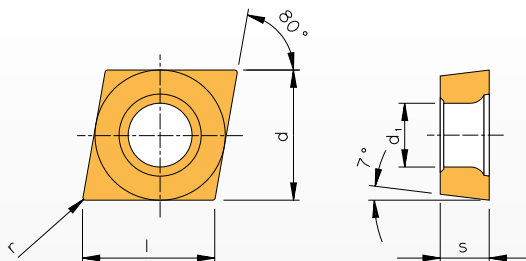
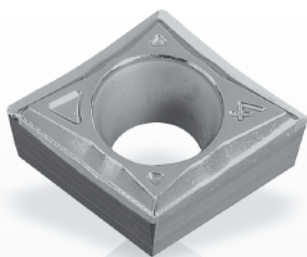

Grade

Designation	l	d	s	d ₁	Grade
CCGT 060201EN-ASF	6,45	6,350	2,38	2,8	AM5015 ●
060202EN-ASF	6,45	6,350	2,38	2,8	●
060204EN-ASF	6,45	6,350	2,38	2,8	●
CCGT 09T302EN-ASF	9,67	9,525	3,97	4,4	●
09T304EN-ASF	9,67	9,525	3,97	4,4	●
				P	●
				M	●
				K	●
				N	●
				S	●
				H	●

DCGT

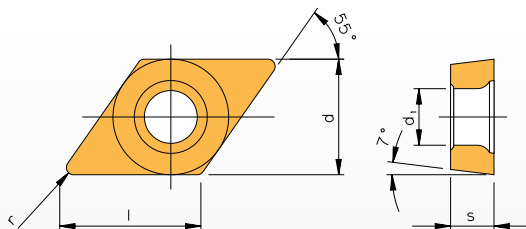
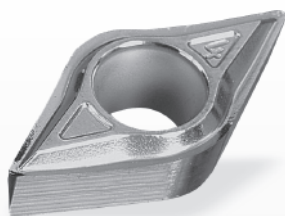

Grade

Designation	l	d	s	d ₁	Grade
DCGT 070201EN-ASF	7,75	6,350	2,38	2,8	AM5015 ●
070202EN-ASF	7,75	6,350	2,38	2,8	●
070204EN-ASF	7,75	6,350	2,38	2,8	●
DCGT 11T302EN-ASF	11,60	9,525	3,97	4,4	●
11T304EN-ASF	11,60	9,525	3,97	4,4	●
				P	●
				M	●
				K	●
				N	●
				S	●
				H	●

VCGT >>

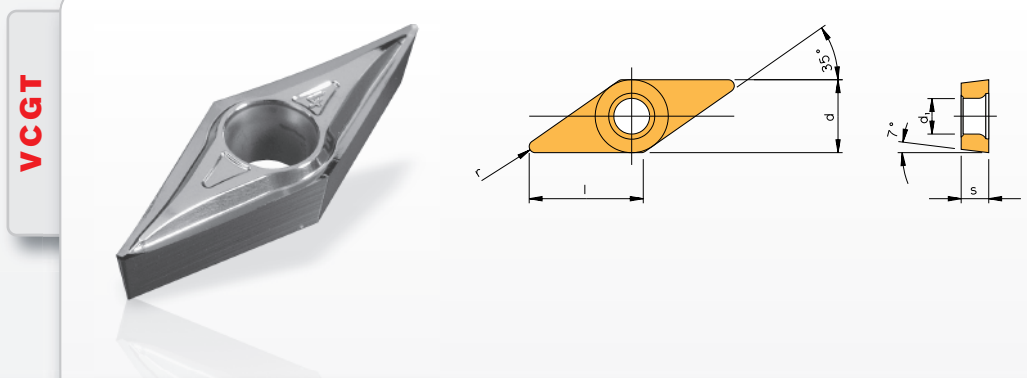

Grade

Designation	l	d	s	d ₁	Grade
VCGT 110301EN-ASF	11,1	6,350	3,18	2,9	AM5015 ●
110302EN-ASF	11,1	6,350	3,18	2,9	●
110304EN-ASF	11,1	6,350	3,18	2,9	●
VCGT 130301EN-ASF	13,1	7,940	3,18	3,2	●
130302EN-ASF	13,1	7,940	3,18	3,2	●
130304EN-ASF	13,1	7,940	3,18	3,2	●
VCGT 160402EN-ASF	16,6	9,525	4,76	4,4	●
160404EN-ASF	16,6	9,525	4,76	4,4	●
				P	●
				M	●
				K	
				N	
				S	●
				H	

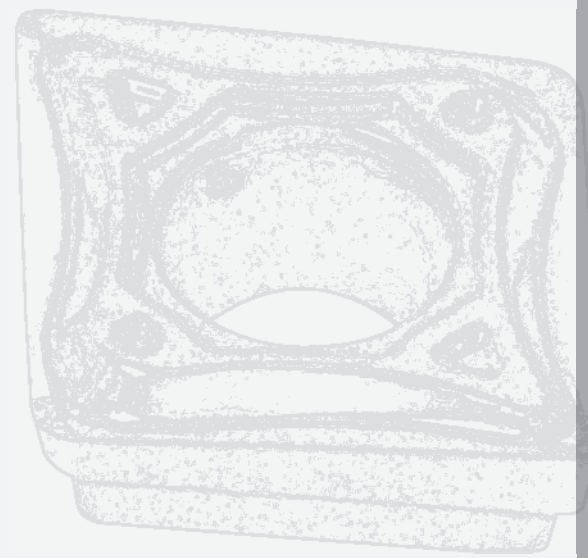

Information >>

ASF-Geometry

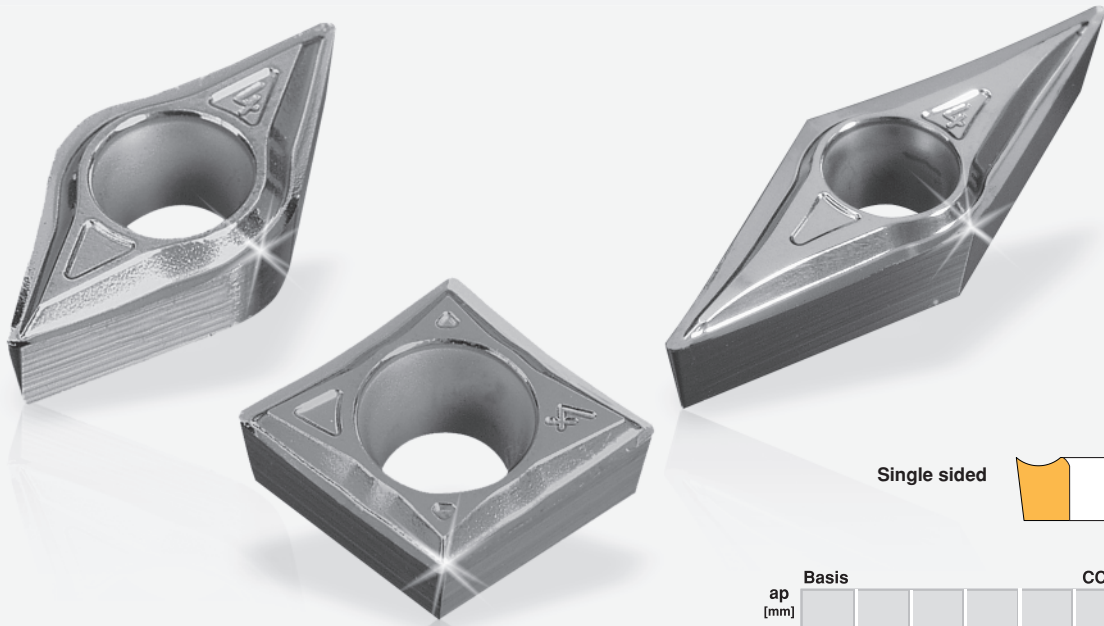

Single sided

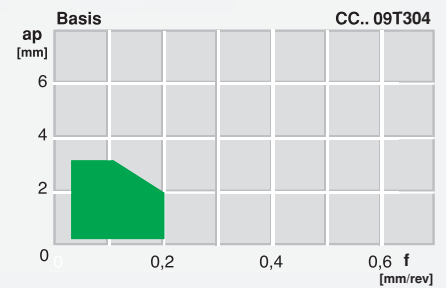
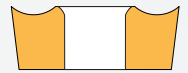

Geometry description

Swarf control and performance (also in “difficult to machine” materials) are achieved successfully using the new “ASF” geometry with “AM5015 Grade”. The geometry has an improved cutting edge condition offering highly stable machining conditions as well as soft, positive, cutting action

Grade description

AM5015 HC - P15, HC - M15, HC - K15, HC - N15, HC - S15

PVD-multilayer TiAlN coating. Wear resistant grade for machining steel, cast steel, stainless steel and high temperature alloys (super alloys).



www.arno.de

Karl-Heinz Arnold GmbH · Karlsbader Str. 4 · D - 73760 Ostfildern
 Fon +49 (0) 711 / 34 802 - 0 · Fax +49 (0) 711 / 34 802 - 130 · info@arno.de · www.arno.de

ARNO (UK) Limited · Unit 3, Sugnall Business Centre · Sugnall, Eccleshall · Staffordshire · ST21 6NF
 Phone +44 (0) 1785 850 072 · Fax +44 (0) 1785 850 076 · sales@arno.de · www.arno-tools.co.uk

ARNO Italia S.r.l. · Via Fiume 13 · 20059 Vimercate (Mi)
 Tel +39 039 / 68 52 101 · Fax +39 039 / 60 83 724 · info@arno-italia.it · www.arno-italia.it

