

ARNO® DECO-Cut® - system

Accuracy and performance!

For machining components on sliding head auto lathes.

With dedicated **ARNO®**-sliding head auto lathe tooling we offer high accuracy and reliable machining of all components, in all materials. This type of lathe often performs highly accurate machining of long, thin and often small components.

- Double sided carbide fine grain inserts
- Excellent repeatability accuracy
- Strong and accurate insert location
- Universal high performance PVD coatings
- Insert geometries for all applications.



ARNO®
WERKZEUGE

www.arno.de

Dedicated tooling and inserts for sliding head auto lathes.

Easy handling and efficient in production!



Tool holder >>

Standard

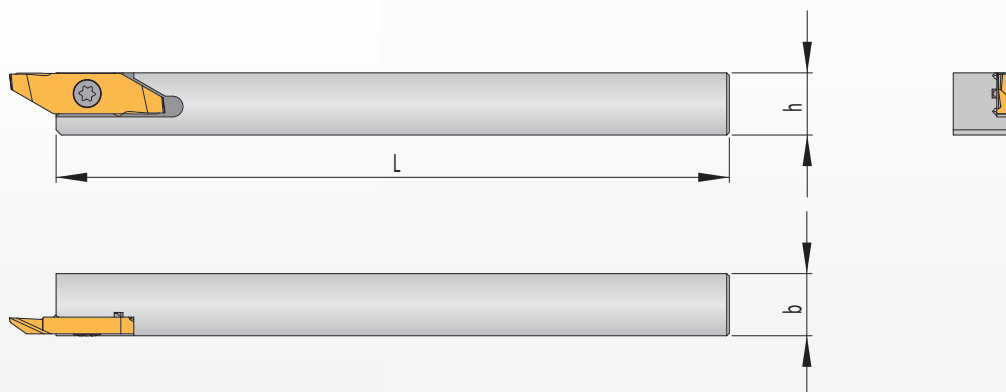

Right hand version

Tool holder

Description	h [mm]	b [mm]	L [mm]	Inserts
SLAO R/L 0808 X08-115	8	8	115	L.. 08....
SLAO R/L 1010 X08-115	10	10	115	L.. 08....
SLAO R/L 1212 X08-130	12	12	130	L.. 08....
SLAO R/L 1212 X08-90	12	12	90	L.. 08....
SLAO R/L 1313 X08-130	13	13	130	L.. 08....
SLAO R/L 1616 X08-130	16	16	130	L.. 08....
SLAO R/L 1616 X08-75	16	16	75	L.. 08....
SLAO R/L 2020 X08-120	20	20	120	L.. 08....

Standard

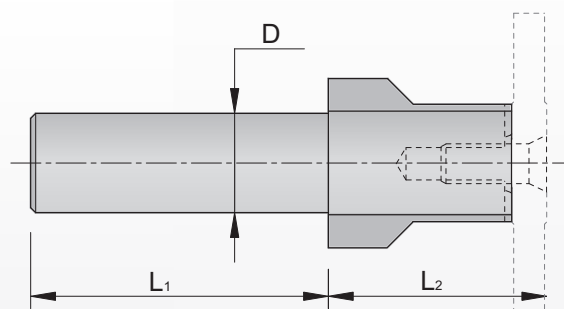

Tool holder

Description	L1 [mm]	L2 [mm]	D [mm]	Inserts
SLCO N 10 X08	30	22	10	L.. 08....

Tool holder >>

Off-Set

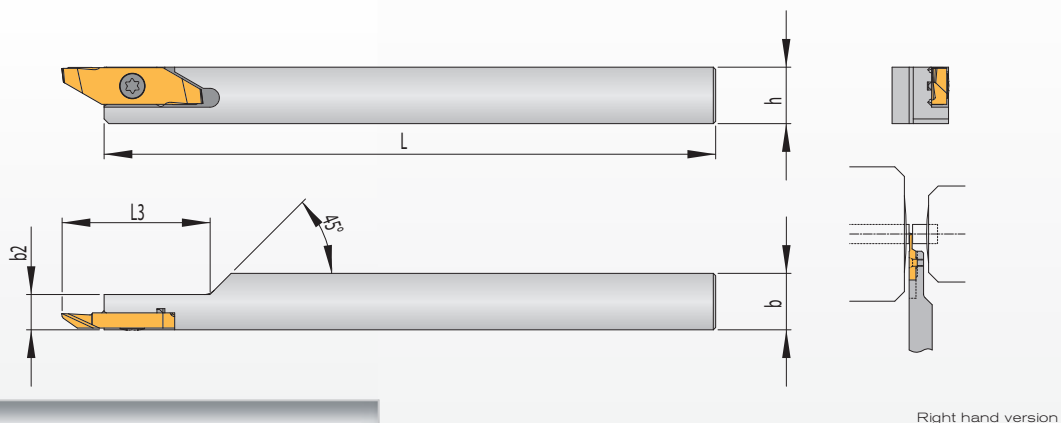

Tool holder

Description	h [mm]	b [mm]	b ₂ [mm]	L [mm]	L ₃ [mm]	Inserts
SLXO R 1212 X08-130	12	12	7,5	130	30	L.. 08....

Off-Set

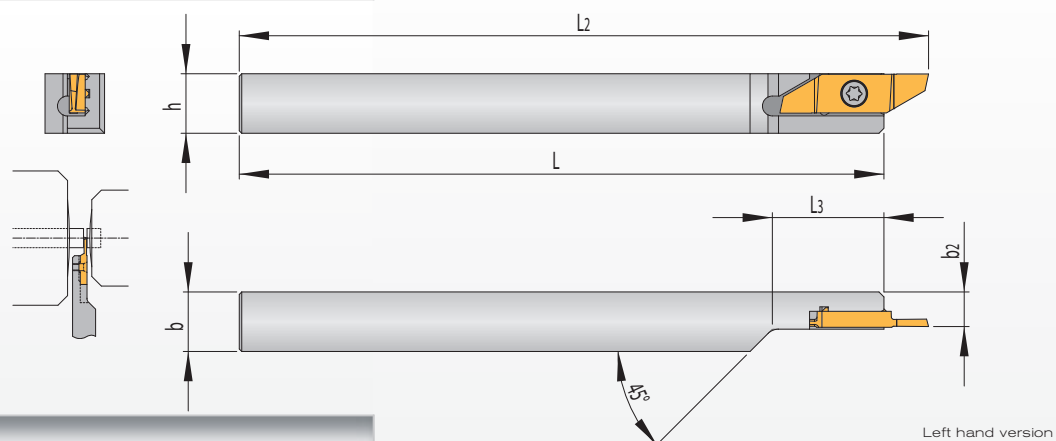

right cut off line

Description	h [mm]	b [mm]	b ₂ [mm]	L [mm]	L ₃ [mm]	Inserts
SLXO L 1212 X08-130	12	12	7,5	130	30	L.. 08....
SLXO L 1616 X08-130	16	16	7,5	130	40	L.. 08....

Spare parts

Description	Screw	Key
SLAO R/L 0808	AS0027	KS1111
SLAO R/L 1010 to 2020	AS0028	KS1111
SLCO N X08	AS0028	KS1111
SLXO	AS0029	KS1111

Inserts >>

Parting off

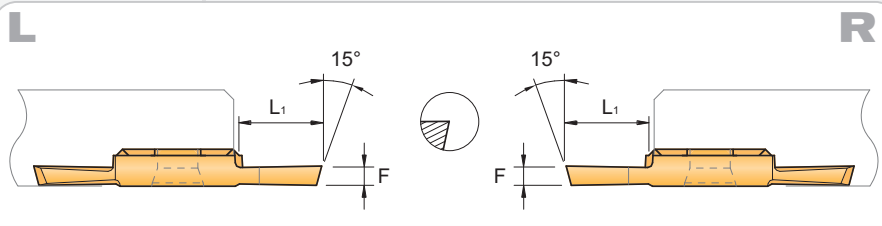

Description	F [mm]	L ₁ [mm]	AP4020	AP5020	AK1020
LAB 080804F R/L	0,8	4,0	●	●	●
LAB 081005F R/L	1,0	5,0	●	●	●
LAB 081205F R/L	1,2	5,0	●	●	●
LAB 081507F R/L	1,5	7,0	●	●	●
LAB 082085F R/L	2,0	8,5	●	●	●
LAB 082585F R/L	2,5	8,5	●	●	●

Parting off

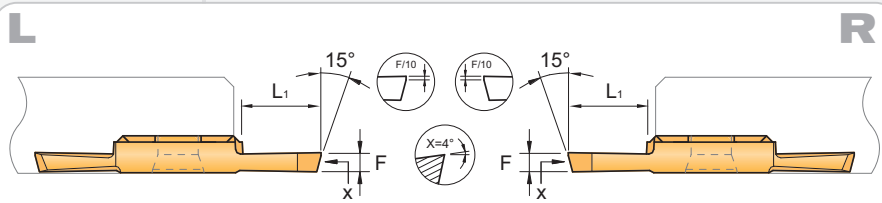

Description	F [mm]	L ₁ [mm]	AP4020	AP5020	AK1020
LAB 081507F R/L -PF	1,5	7,0	●	●	●
LAB 082085F R/L -PF	2,0	8,5	●	●	●

Parting off

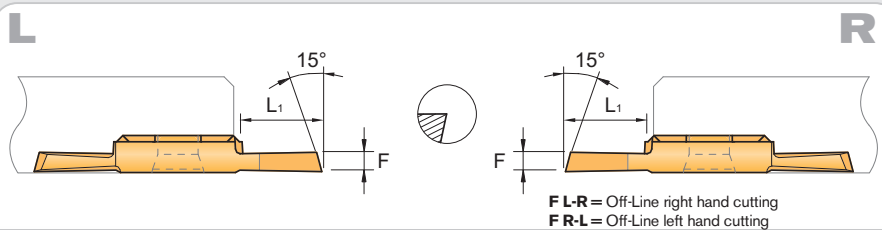

FL-R = Off-Line right hand cutting
FR-L = Off-Line left hand cutting

Description	F [mm]	L ₁ [mm]	AP4020	AP5020	AK1020
LAB 081507F L-R	1,5	7,0	●	●	●
LAB 082085F L-R	2,0	8,5	●	●	●
LAB 082085F R-L	2,0	8,5	●	●	●

Parting off

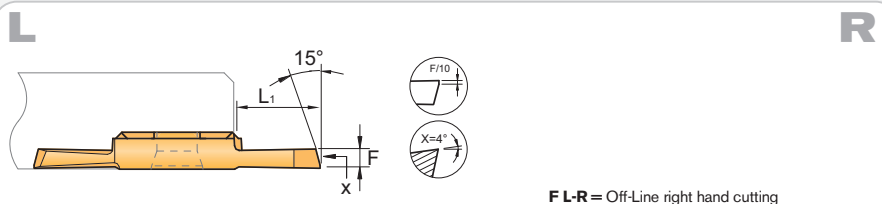

FL-R = Off-Line right hand cutting
FR-L = Off-Line left hand cutting

Description	F [mm]	L ₁ [mm]	AP4020	AP5020	AK1020
LAB 081507F L-R -PF	1,5	7,0	●	●	●
LAB 082085F L-R -PF	2,0	8,5	●	●	●

Inserts >>

Groove and turn

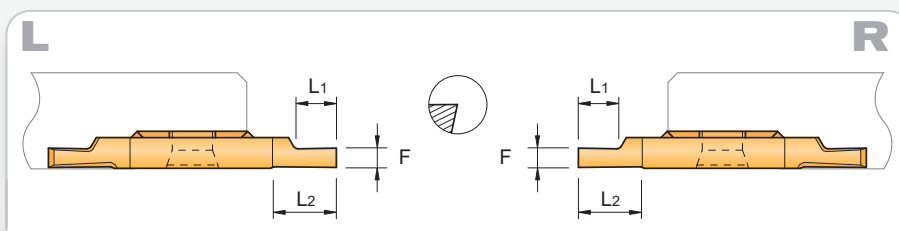

Description	F [mm]	L1 [mm]	L2 [mm]	AP4020	AP5020	AK1020
LST 080802F R/L	0,8	2,0	4,0	●	●	●
LST 081025F R/L	1,0	2,5	4,0	●	●	●
LST 081230F R/L	1,2	3,0	4,0	●	●	●
LST 081530F R/L	1,5	3,0	4,0	●	●	●
LST 082040F R/L	2,0	4,0	6,5	●	●	●
LST 082560F R/L	2,5	6,0	6,5	●	●	●
LST 083065F R/L	3,0	6,5	6,5	●	●	●

Groove and turn

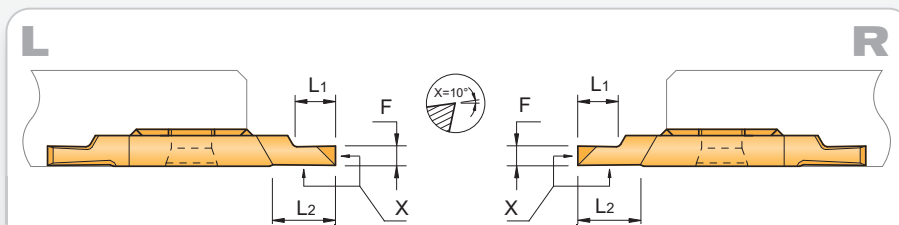

Description	F [mm]	L1 [mm]	L2 [mm]	AP4020	AP5020	AK1020
LST 081025F R/L -P	1,0	2,5	4,0	●	●	●
LST 081230F R/L -P	1,2	3,0	4,0	●	●	●
LST 081530F R/L -P	1,5	3,0	4,0	●	●	●
LST 082040F R/L -P	2,0	4,0	6,5	●	●	●
LST 082560F R/L -P	2,5	6,0	6,5	●	●	●
LST 083065F R/L -P	3,0	6,5	6,5	●	●	●

Inserts >>

Front turning

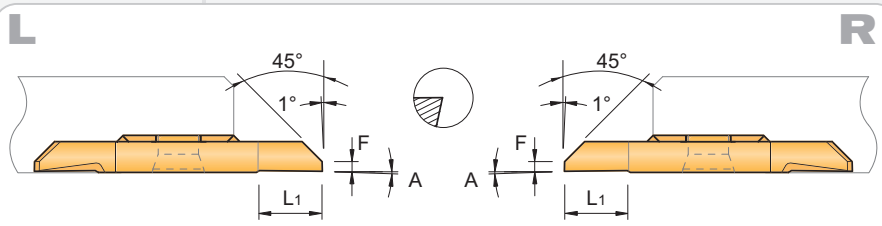

Description	F [mm]	L1 [mm]	A	AP4020	AP5020	AK1020
LVD 08-0F R/L	1,0	6,5	0°	●	●	●
LVD 08-2F R/L	1,0	6,5	2°	●	●	●

Front turning

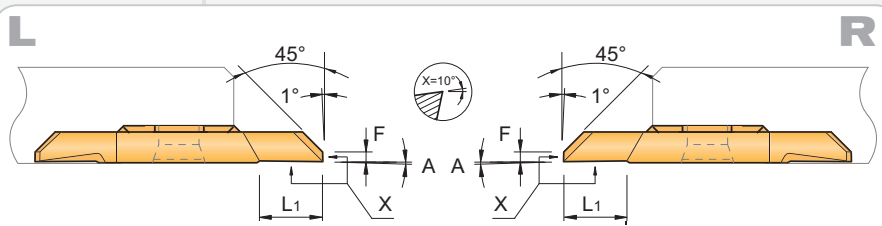

Description	F [mm]	L1 [mm]	A	AP4020	AP5020	AK1020
LVD 08-0F R/L -P	1,0	6,5	0°	●	●	●
LVD 08-2F R/L -P	1,0	6,5	2°	●	●	●

Thread turning

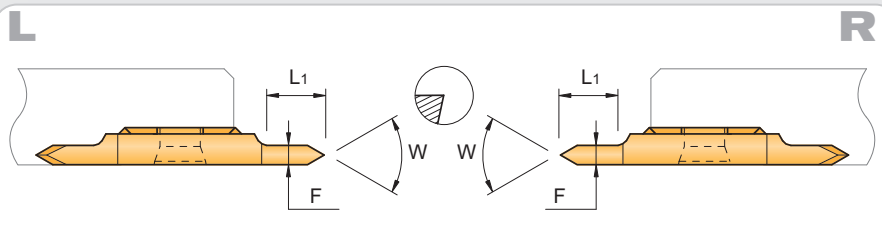

Description	F [mm]	L1 [mm]	W	AP4020	AP5020	AK1020
LGE 08-60F R/L	2,0	6,0	60°	●	●	●

Grade description DECO-Cut

AP4020

PVD coating, carbide + TiN

Universal grade for light machining of none ferrous materials (copper and copper alloys, bronze and brass) as well as aluminium and aluminium alloys at low cutting speed. Very suitable for machining soft materials with a tendency to create build up edge on the cutting edge. Also suitable for machining small diameter components in free cutting steel. Very low co-efficiency.

AP5020

PVD coating, carbide + TiAlN

Suitable for general steel cutting, but also suitable for machining stainless steel, high temperature alloys as well as titanium alloys. Very good heat resistance.

AK1020

Uncoated grade

Wear resistance fine grain grade. Suitable for machining aluminium, aluminium alloys and exotic materials (titanium). Base grade for customer specific coating solutions.

Inserts >>

Back turning

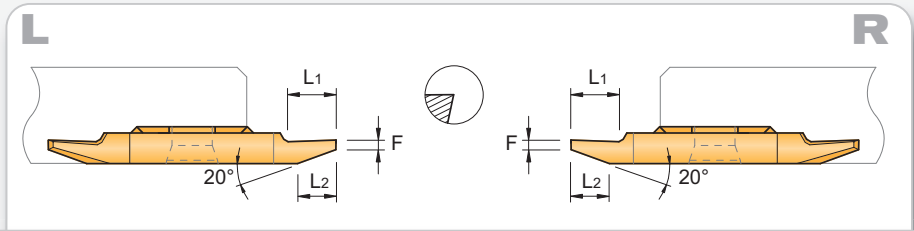

Description	F [mm]	L1 [mm]	L2 [mm]	AP4020	AP5020	AK1020
LRD 080504F R/L	0,5	4,0	4,0	●	●	●
LRD 081050F R/L	1,0	5,0	4,0	●	●	●

Back turning

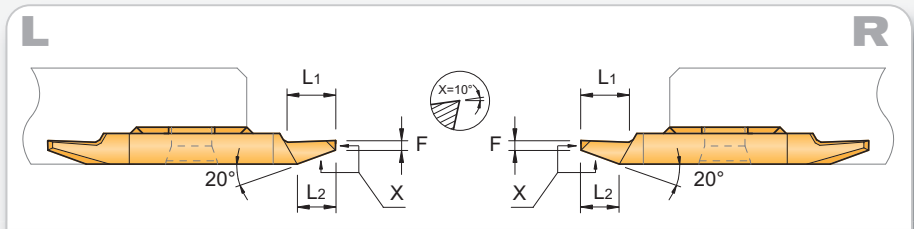

Description	F [mm]	L1 [mm]	L2 [mm]	AP4020	AP5020	AK1020
LRD 081050R R/L -P	1,0	5,0	4,0	●	●	●

Back turning

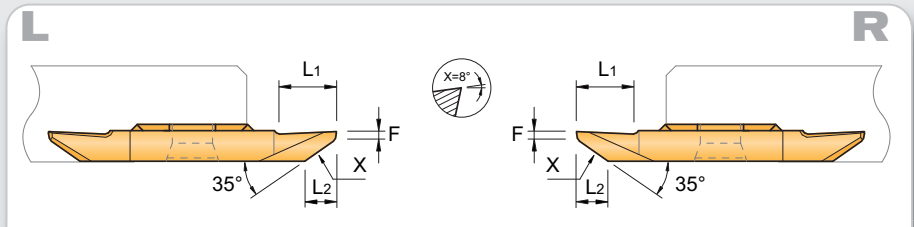

Description	F [mm]	L1 [mm]	L2 [mm]	AP4020	AP5020	AK1020
LRD 081060F R/L -SP	1,0	6,0	3,0	●	●	●

Blanks

Blanks

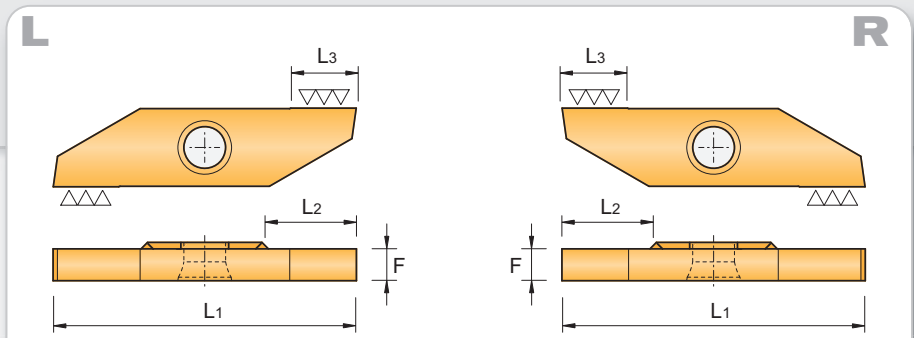

Description	F [mm]	L1 [mm]	L2 [mm]	L3 [mm]	AP4020	AP5020	AK1020
LRO 08F R/L	~3,2	~30,5	~9,2	~6,5	●	●	●

Information >>

Advantages of the DECO-Cut >>

- Double sided carbide fine grain inserts
- Strong and accurate insert location
- Universal high performance PVD coatings
- Choice of many geometries.

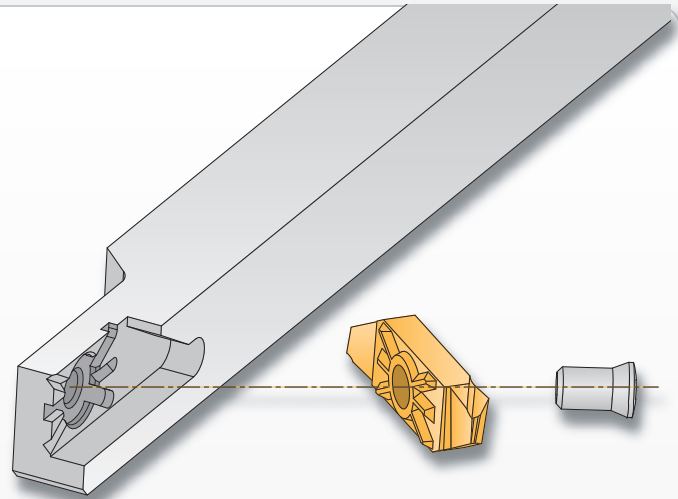

Cutting recommendations:

Roughing:

- Medium cutting speed
- High feed rate

Finishing:

- High cutting speed
- Reduced feed rate

Cutting data

ISO		Turning		Parting off	
		V _c [m/min]	f [mm/U]	V _c [m/min]	f [mm/U]
P	Free cutting steel	120 - 200	0,01 - 0,20	80 - 150	0,01 - 0,15
	Steel < 600 N/mm ²	80 - 160	0,01 - 0,18	70 - 120	0,01 - 0,12
	Steel < 800 N/mm ²	60 - 120	0,01 - 0,15	60 - 100	0,01 - 0,10
	Steel > 800 N/mm ²	50 - 100	0,01 - 0,12	40 - 80	0,01 - 0,08
M	Stainless steel	60 - 120	0,01 - 0,15	60 - 100	0,01 - 0,08
N	Aluminium and Aluminium alloys	180 - 800	0,01 - 0,30	150 - 300	0,01 - 0,20
	Copper and Copper alloys (Brass, Bronze)	100 - 500	0,01 - 0,30	100 - 300	0,01 - 0,20
S	Titanium	30 - 70	0,01 - 0,12	30 - 50	0,01 - 0,06

